

S300 PA

The **S300 PA** series of advanced **MAXI** photoelectric sensors represents the most suitable solution for standard applications thanks to its excellent cost/performance ratio. The new series offers a wide range of models and functions in order to guarantee easy use and installation. The new series presents **5** different models with **through beam** optical function up to **50m**, **retroreflex** up to **15m**, **polarized retroreflex** up to **10m**, **diffused proximity** at **2m** and **background suppression** at **2m**. All the models are available both **Vdc** from **12 to 30V** and **Vac/Vdc** free-voltage from **24 to 240V** versions. A timing function version with both the **SPDT** relay or the bipolar transistor **NPN/PNP** open collector outputs is offered. The **terminal block connection** simplifies and speeds-up the installation procedure, whereas the **heavy-duty plastic housing** guarantees excellent resistance under harsh use conditions.



HIGHLIGHTS

- Excellent optical performances
- Sturdy plastic housing with **IP67** mechanical protection
- Wide range of operating temperatures ranging from **-25 to 55°C**
- Timing function from 0.6-16 s **ON-delay**, **OFF delay** **ONE SHOT**
- **Terminal block** for both **Vdc** and **Vac/Vdc free voltage versions**
- Distance trimmer clutch for mechanical background suppression models

APPLICATIONS



DIMENSIONS

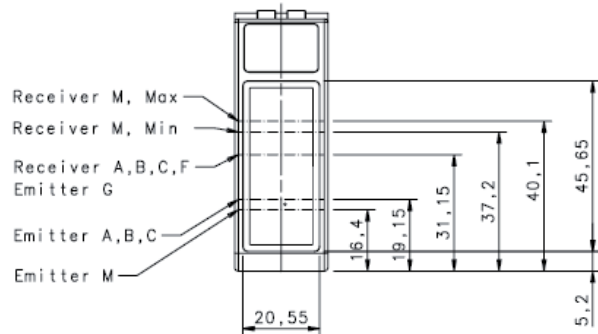
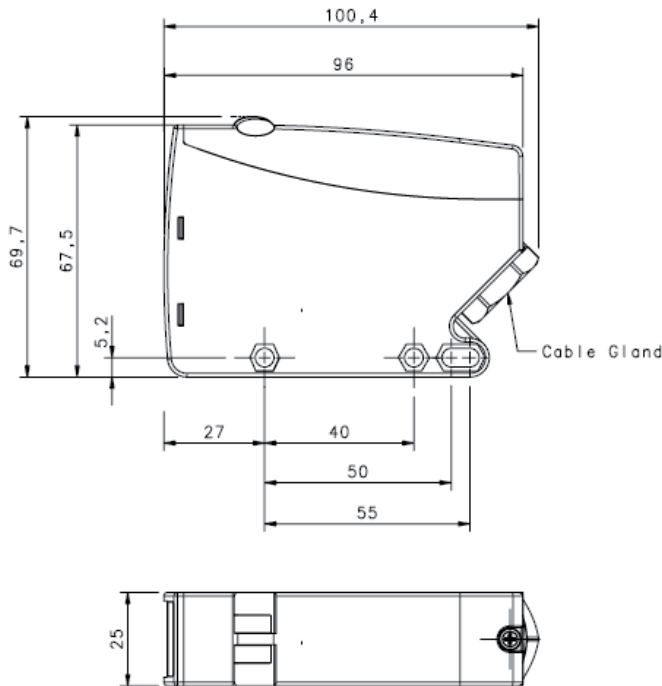

mm

SETTINGS

The **M** model presents a **multiturn adjustment screw** for the adjustment of the background suppression distance using a mechanical variation of the optic triangulation angle. The **other models have a mono-turn electronic trimmer** that adjusts the sensitivity and the sensor operating distance. The operating distance can be increased by rotating the screws clockwise. Trimmers can be used to adjust the output activation and deactivation delay time whilst functioning mode selection is performed through DIP SWITCHES.

CONTROLS

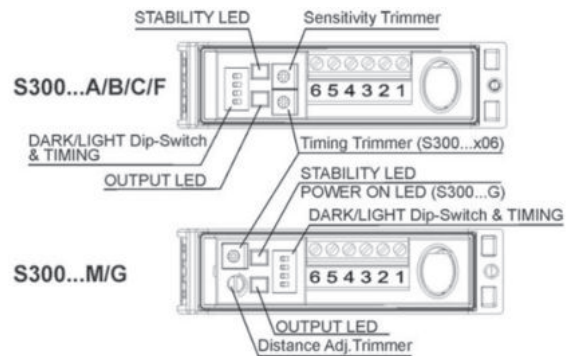

CONNECTIONS G

AC MODELS

DC MODELS

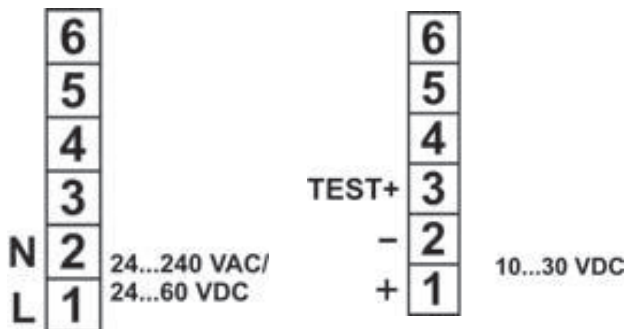

CONNECTIONS A, B, C, M, F

AC MODELS

DC MODELS

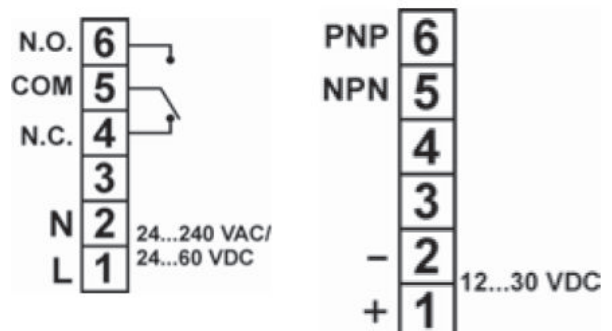

TECHNICAL DATA

COMMON DATA	S300-A	S300-B	S300-C	S300-M	S300-F	S300-G
Emission type:	IR LED (880nm)	Red LED (660nm)	IR LED (940nm)	IR LED (880nm)		IR LED (880nm)
Operating distances (typical values):	0.1...15m	0.1...10m	5...200cm	20...200cm	0...50m	
Setting:	Mono-turn sensitivity trimmer			7-turns adjustment trimmer	Mono-turn sensitivity trimmer	
	DARK/LIGHT Dip switch Dip-switch mode ON delay / OFF delay / ON-OFF delay / Single pulse (ONE-SHOT) (S300...x06)					
Time Delay Range (timing vers.):	0.6...16 s (adjustment by Trimmer)					
White/Black difference (90% / 4%)	< 15%					
Indicators:	OUTPUT LED (yellow) STABILITY LED (green)					POWER ON LED (green)
Operating temperature:	-25...55°C					
Storage temperature:	-25...70°C					
Dielectric strength:	1500Vac 1 min between electronics and housing					
Insulating resistance:	>20MΩ 500Vdc between electronics and housing					
Ambient light rejection:	according to EN 60947-5-2					
Vibrations:	0.5mm width, 10 ... 55Hz, for each axis (EN60068-2-6)					
Shock resistance:	11ms (30G) 6 shocks for each axis (EN60068-2-27)					
Housing material:	PBT (30% fibre-reinforced glass)					
Lens material:	PC					
Mechanical protection:	IP67 (IEC / EN60529) / NEMA TYPE 1 (For UL / c-UL)					
Connections:	Terminal block (recommended cable diameter: between 8 and 10mm)					

AC VOLTAGE MODELS	S300-A	S300-B	S300-C	S300-M	S300-F/G
Power supply:	24...240Vac / 24...60Vdc				
Ripple:	10% max				
Consumption (output current excluded):	< 3VA				
Outputs:	SPDT electromagnetic relay: 250Vac, 30Vdc				
Output current:	3A (resistive load)				
Response time:	25ms max				
Switching frequency:	20Hz				
Weight:	130g				

DC VOLTAGE MODELS	S300-A	S300-B	S300-C	S300-M	S300-F/G
Power supply:	12...30Vdc				
Ripple:	10% max				
Consumption (output current excluded):	< 35mA				
Outputs:	PNP and NPN open collector				
Output current:	100mA (resistive load)				
Output saturation voltage:	< 2.4V max				
Response time:	1ms max				2ms max
Switching frequency:	500Hz				250Hz
Weight:	120gr				

DETECTION DIAGRAMS

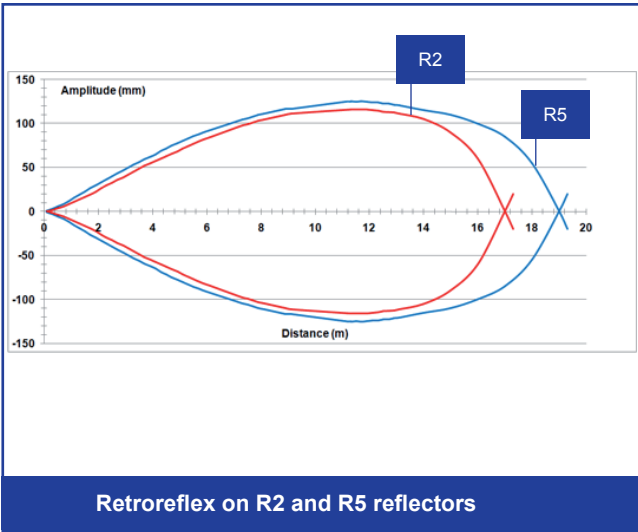

Retroreflex on R2 and R5 reflectors

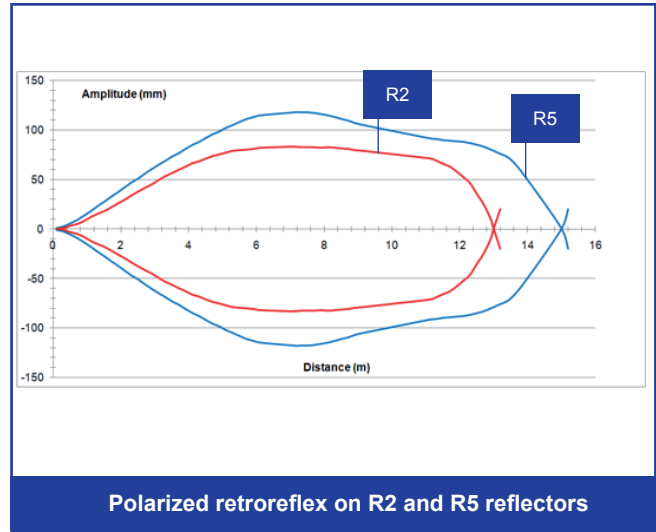

Polarized retroreflex on R2 and R5 reflectors

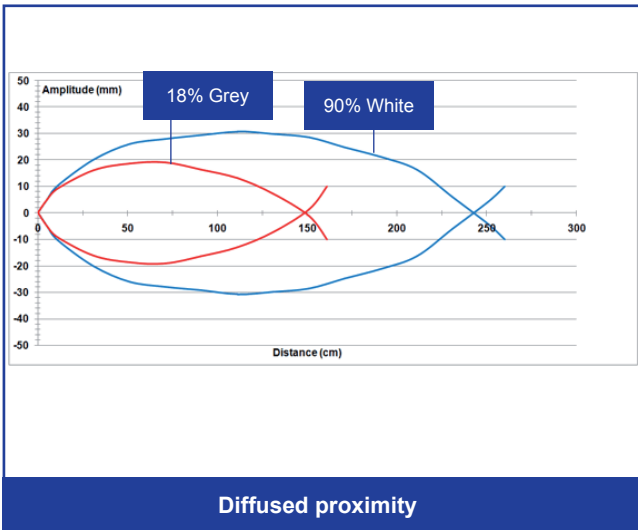

Diffused proximity

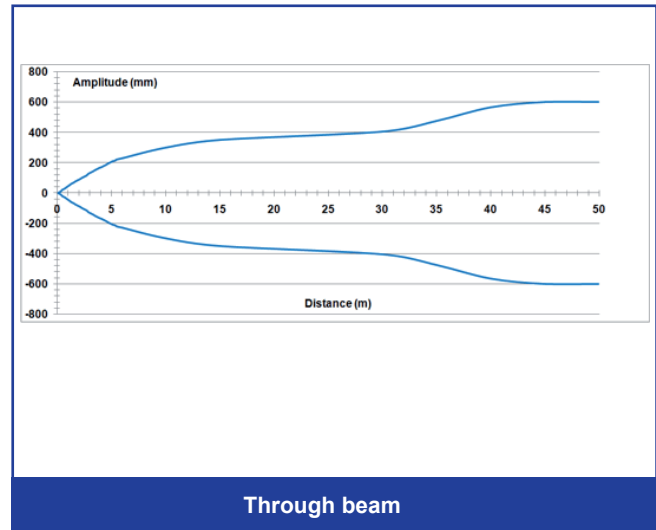

Through beam

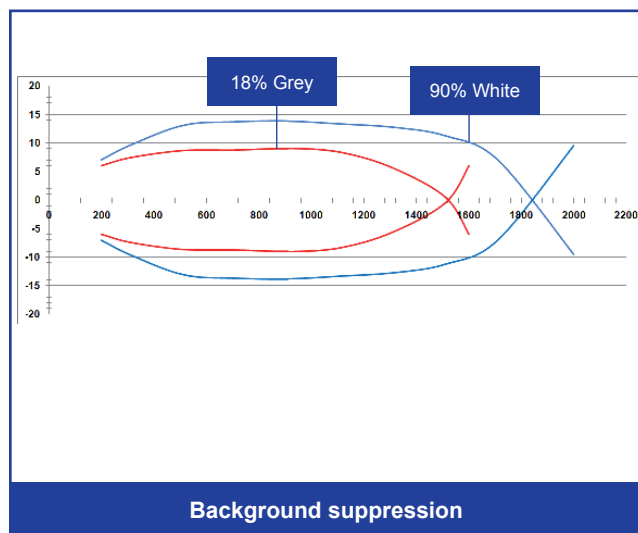

Background suppression

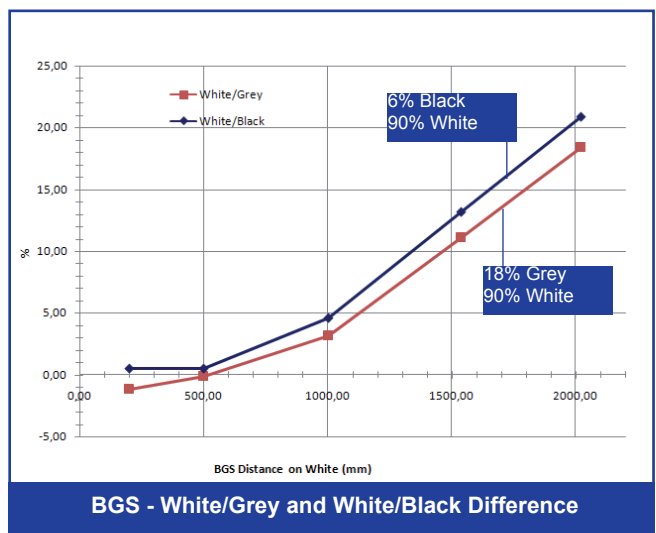

BGS - White/Grey and White/Black Difference

TIMING FUNCTION DIAGRAM

Five selectable timing functions: one shot, ON delay, OFF delay, ON/OFF delay and normal mode. **Trimmer adjustment** of the functions is available. The timing functions can be particularly useful in applications where the output signal pulse has to be modified.

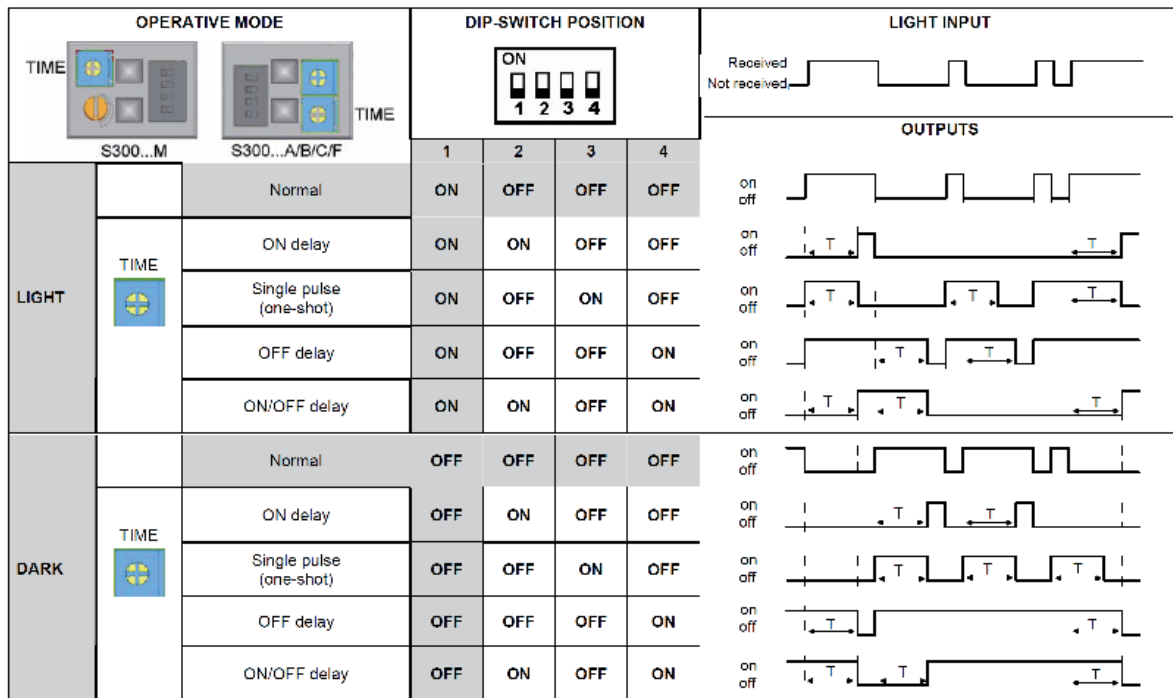

ACCESSORY SELECTION AND ORDER INFORMATION

MODEL	DESCRIPTION	ORDER N°
ST-511	S2 FIXING BRACKET	95ACC2810

ACCESSORY DRAWINGS

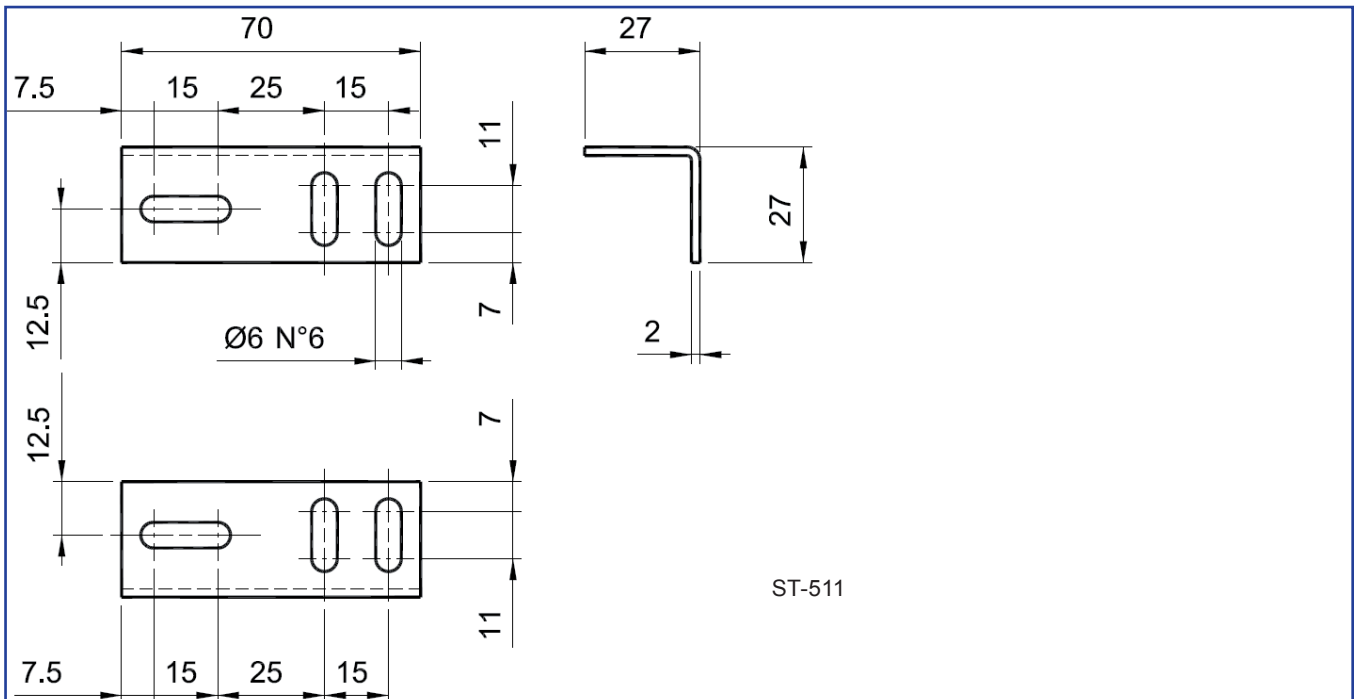

MODEL SELECTION AND ORDER INFORMATION

S300-PA-X-XXX-XX

CONNECTION

- 1** = AC/DC Terminal Block
- 2** = DC Terminal Block

TIMING

- 00** = No ADJ, no Timing
- 01** = ADJ, no Timing
- 06** = ADJ, Timing

HOUSING/OPTICS

PA = Plastic/Axial

OPTIC FUNCTION

- A** = Retro-Reflex
- B** = Polarized Retro-Reflex
- C** = Diffused Proximity
- M** = Background Suppression
- F** = Receiver
- G** = Emitter

OUTPUT/INPUT

- OC** = PNP/NPN
- RX** = Relay NO/NC
- EX** = No outputs

ORDER NO.	MODEL	DESCRIPTION
951451480	S300-PA-1-A01-RX	RRX 24-240VAC/VDC
951451490	S300-PA-1-A06-RX	RRX 24-240VAC/VDC TIMER
951451500	S300-PA-2-A01-OC	RRX 12-30VDC
951451510	S300-PA-2-A06-OC	RRX 12-30VDC TIMER
951451520	S300-PA-1-B01-RX	POL 24-240VAC/VDC
951451530	S300-PA-1-B06-RX	POL 24-240VAC/VDC TIMER
951451540	S300-PA-2-B01-OC	POL 12-30VDC
951451550	S300-PA-2-B06-OC	POL 12-30VDC TIMER
951451400	S300-PA-1-C01-RX	DIFF 24-240VAC/VDC
951451410	S300-PA-1-C06-RX	DIFF 24-240VAC/VDC TIMER
951451420	S300-PA-2-C01-OC	DIFF 12-30VDC
951451430	S300-PA-2-C06-OC	DIFF 12-30VDC TIMER
951451440	S300-PA-1-M01-RX	BGS 24-240VAC/VDC
951451450	S300-PA-1-M06-RX	BGS 24-240VAC/VDC TIMER
951451460	S300-PA-2-M01-OC	BGS 12-30VDC
951451470	S300-PA-2-M06-OC	BGS 12-30VDC TIMER
951451560	S300-PA-1-G00-EX	EMITTER 24-240VAC/VDC
951451570	S300-PA-2-G00-EX	EMITTER 12-30VDC
951451580	S300-PA-1-F01-RX	REC 24-240VAC/VDC
951451590	S300-PA-1-F06-RX	REC 24-240VAC/VDC TIMER
951451600	S300-PA-2-F01-OC	REC 12-30VDC
951451610	S300-PA-2-F06-OC	REC 12-30VDC TIMER

The company endeavours to continuously improve and renew its products; for this reason the technical data and contents of this catalogue may undergo variations without prior notice. For correct installation and use, the company can guarantee only the data indicated in the instruction manual supplied with the products.

